

Mordaza estándar serie 34 Standard vice



Características Characteristics



Esta mordaza por separado no incluye llave. / This vice does not include the wrench separately.

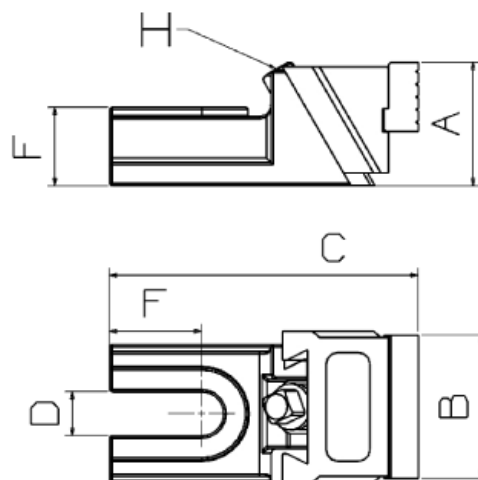

Ref.	A	B	C	D	E	F	S Din 471	M Din 912		Rosca / Thread	Peso Weight
346000	50-68	60	135	18	42	45	D15	M8	12	TR14x3	2,0
347900	65-85	79	168	25	45	57	D20	M10	12	TR18x4	4,4
3411200	89-120	120	246	30	65	75	D25	M12	17	TR22x5	12,7

Despiece Spare parts

- 01 Cuerpo Fundición GGG40. Pintado con cataforesis. Negro.
- 02 Carro Fundición GGG40. Pintura roja.
- 03 Husillo F125 Normalizado. HRc40. Pavonado
- 07 Soporte ETG100 31HRc.Pavonado
- 14 Bocas F114 HRc 42. Pavonadas.
- 19 LLave. F114 natural. Niquelada
- 01 Body made of cast iron GGG40. Paint treated (Cataphoresis). Black.
- 02 Movable part made of cast iron GGG40. Red paint .
- 03 Spindle F125 Normalized steel. HRc40. Black oxide
- 07 Support ETG100 31HRc. Black oxide
- 14 Jaws F114 HRc 42. Black oxide
- 19 Wrench. F114. Nickel plate

